



BOROUGH OF RINGWOOD

Building Department ■ Code Enforcement

Phone (973) 962-7880 Fax (973) 962-7823 building@ringwoodnj.net

POOL PACKET

For a step-by-step guide, go to the FAQ section on the Building Department web page, and click on "Pools and Hot Tubs – Start to Finish."

SECTION ONE

STEP ONE: PRIOR APPROVALS

- You must first obtain prior approval before submitting a permit application. See Section Two for the required application.
- We will call you when you can proceed to Step 2

STEP TWO: ENGINEERING REVIEW, IF REQUIRED

- Pool/Patio installations disturbing 500 sq. ft. or more of land require Engineering Review:
 1. Four sealed topographical preliminary site plans showing proposed location of the pool:
3 hard copy, one electronic copy
 2. Four sealed foundation location surveys (typically not required; we will tell you if it is):
3 hard copy, 1 electronic copy
 3. Four sealed "As Built" surveys before Certificate of Approval can be issued:
3 hard copy, 1 electronic copy
 4. A fee of \$150 for Engineering Review
- We will call you when you can proceed to Step 3

STEP THREE: PLAN REVIEW

- Submit permit application along with two (2) sets of sealed plans

FOR YOUR INFORMATION

- Low voltage landscape lighting requires an electrical permit if over 10 volts
- It is the property owner's responsibility to ensure that all required inspections are scheduled throughout construction and upon completion of the work
- New Jersey Uniform Construction Code requires a stamped, approved set of plans be on site at all times for use during inspections NJAC 5:23-2.16(e)



BOROUGH OF RINGWOOD
Building Department ■ Code Enforcement
60 Margaret King Avenue, Ringwood NJ 07456
Phone (973) 962-7880 Fax (973) 962-7823



Pool Fence Requirements

Private swimming pools must be surrounded by a barrier, such as a fence or wall. The barrier must meet the following requirements.

- The top of the barrier shall be at least 48 inches above finished ground level measured on the side of the barrier, which faces away from the swimming pool. The maximum vertical clearance between finished ground level and the bottom of the barrier shall be 2 inches measured on the side of the barrier, which faces away from the swimming pool.
- Solid barriers shall not contain indentations or protrusions except for normal construction tolerances and tooled masonry joints.

Fences with horizontal rails less than 45" apart

Where the barrier is composed of horizontal and vertical members and the distance between the tops of the horizontal members is less than 45 inches, the horizontal members shall be located on the swimming pool side of the fence. Spacing between vertical members shall not exceed 1-³/₄ inches in width. Decorative cutouts shall not exceed 1-³/₄ inches in width.

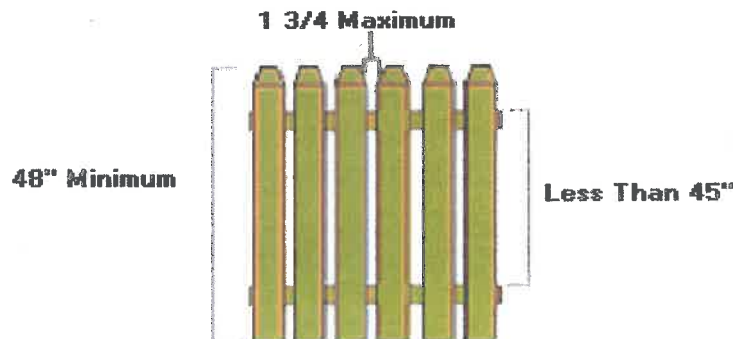

If horizontal planks are less than 45" apart the vertical spacing cannot be more than 1-3/4"

Fences with horizontal rails more than 45" apart

Where the barrier is composed of horizontal and vertical members and the distance between the tops of the horizontal members is 45 inches or more, spacing between vertical members shall not exceed 4 inches. Decorative cutouts shall not exceed 1- $\frac{3}{4}$ inches in width.

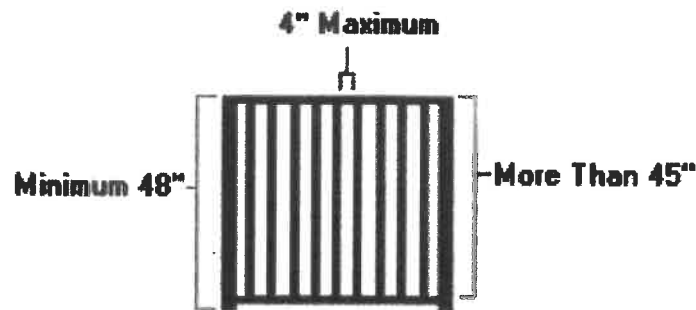

**If horizontal rails are more than 45" apart
the vertical spaces cannot be more than
4" apart**

Chain link Fence Mesh Size Limit

Maximum mesh size for chain link fences shall be a 1 $\frac{1}{4}$ -inch square unless the fence is provided with slats fastened at the top or the bottom which reduce the openings to not more than 1 $\frac{3}{4}$ -inches. (Figure 3)

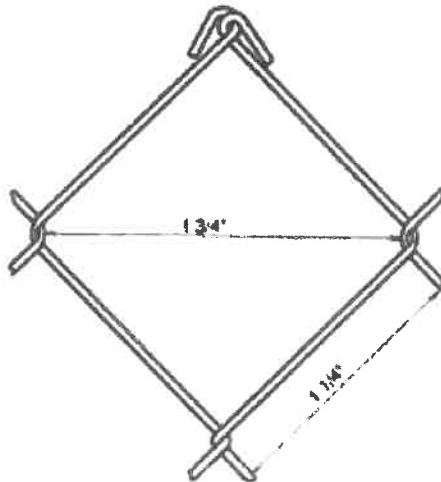

Important: The maximum mesh size for a pool fence is smaller than the standard chain link mesh

Gate Swing

Gates shall comply with the requirements of a fence for height, picket spacing or chain link mesh size and shall be equipped to accommodate a locking device. Pedestrian access gates shall open outwards away from the pool and shall be self-closing and have a self-latching device. Gates must swing out only so that even if the gate is not completely latched, a young child pushing on the gate in order to enter the pool area will at least close the gate and may actually engage the latch.

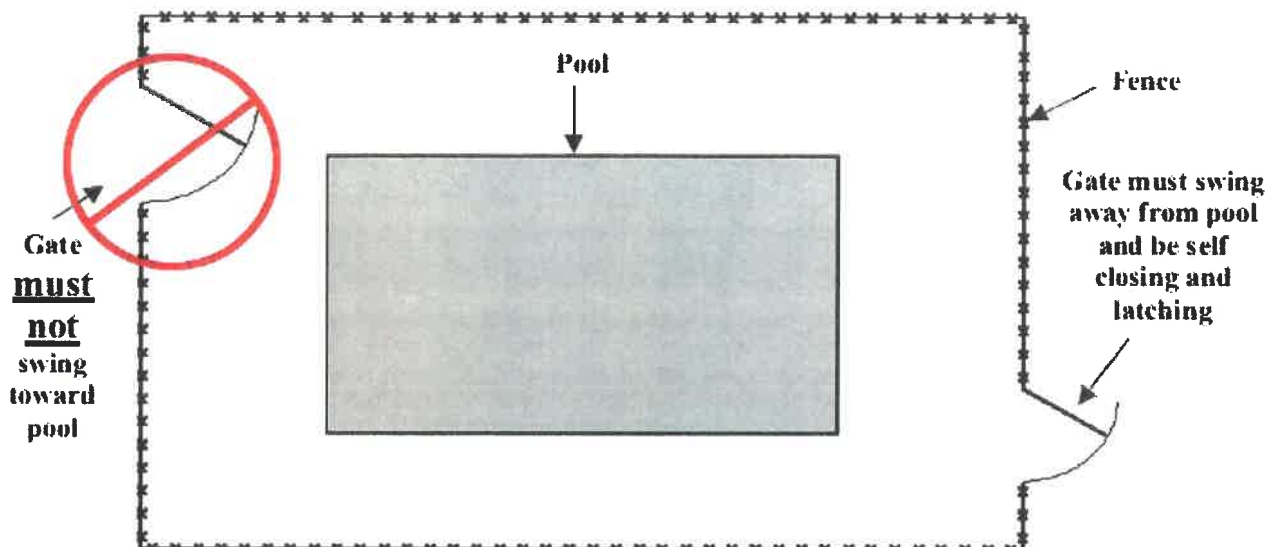

48" high gates with latches mounted less than 54" from the ground

If the latch is mounted less than 54" from grade, it must be mounted on the pool side of the gate, a minimum of 3" down from the top of the gate so you must reach over the fence to unlatch and have no space greater than 1/2" within 18" of the latch so a child can not reach through the fence to unlatch it.

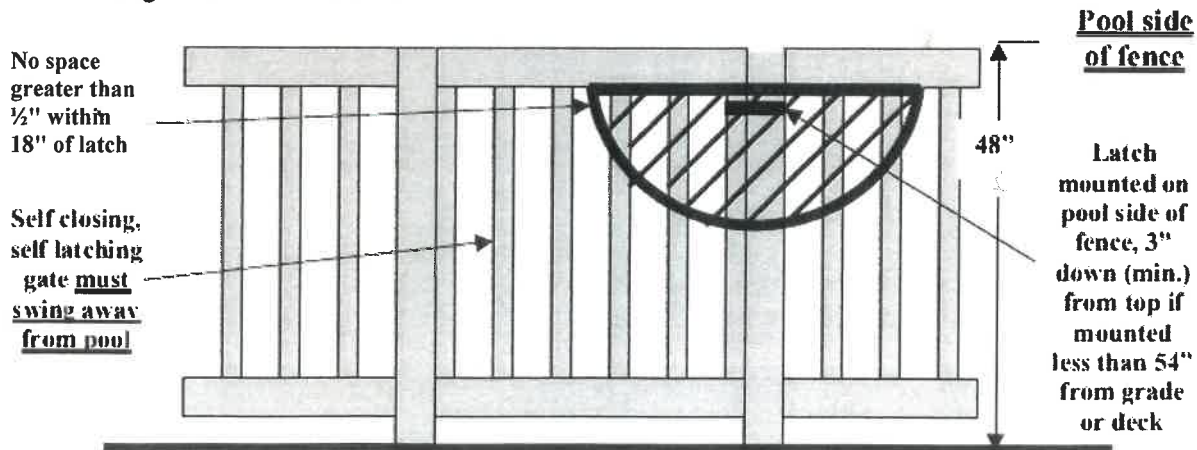

48" high gates with the latch mounted above the top of the gate.

Several manufacturers make latches that can be mounted on a 48" high gate and have the operating mechanism above the top of the gate. The operating mechanism must be mounted at least 54" above the bottom of the gate.



Gates more than 48" high

Gates that are more than 48" high must have the latch mounted at least 54" above the bottom of the gate.



Above ground pools

Barriers are required for above ground pools. **A removable ladder is not an acceptable barrier for an above ground pool.** The barrier may be a compliant fence that surrounds the entire pool or yard. Pools that have a wall that is at least 48" do not require a fence around the entire pool and may have a fence just around the ladder area or a ladder with a built-in self-closing latching gate.

Above ground pools with walls at least 48" above grade

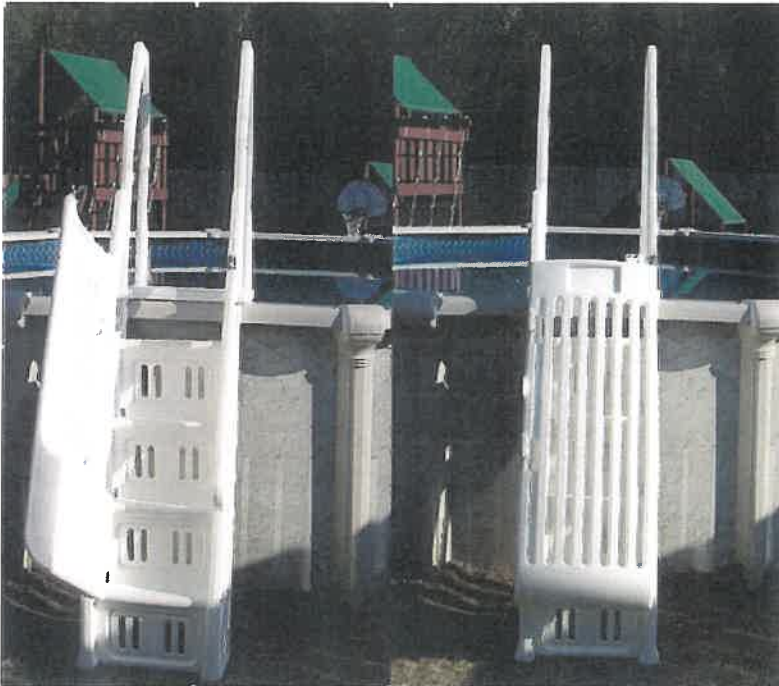

Ladder with built-in gate



Fence around ladder area

Above ground pools on sloped site

Where the walls of an above-ground pool are used as the barrier, are on a sloped site, which will make a portion of the top of the pool structure to be less than 48" to grade, a minimum of 3-foot level surface around the portion of the pool structure that is less than 48" to grade should be provided. The level surface should be measured away from the pool wall to the excavation edge and should be tapered away from the pool at a minimum of 45-degree angle for a distance of one half the level surface.

Above ground pools on sloped site where the pool wall is used as the barrier

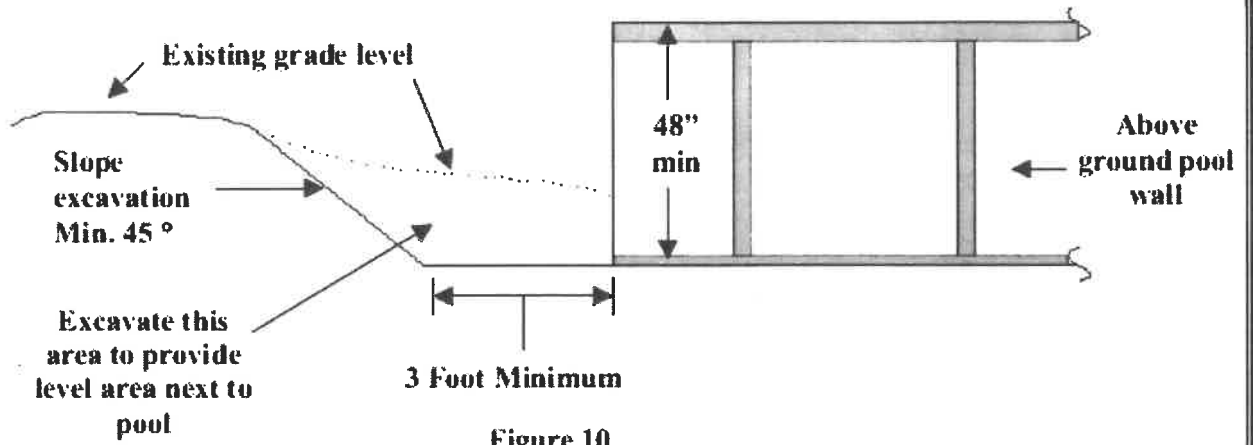

Figure 10

FOR OWNER'S INFORMATION

2012 INTERNATIONAL SWIMMING POOL AND SPA CODE

SECTION 303 ENERGY

303.1 General. The energy requirements for pools and inground permanently installed *spas* shall be as specified in Sections 303.2 through 303.4 and APSP 15. The energy requirements for *residential* portable electric *spas* shall be in accordance with APSP 14.

303.2 Heaters. Heaters shall be equipped with an external on-off switch to allow the heater to be shut off without adjusting the thermostat setting. Such switch shall be provided with ready access. Gas-fired heaters shall not be equipped with continuous pilot burners.

Exception: *Portable residential spas* and *portable residential exercise spas*.

303.3 Time switches. Time switches or other control methods that can automatically turn off and on heaters and pumps according to a preset schedule shall be installed with or on all heaters and pumps. Heaters, pumps and motors that have built-in timers shall be deemed in compliance with this requirement.

Exceptions:

1. Where public health standards require 24-hour pump operation.
2. Pumps that operate waste-heat recovery pool heating systems.
3. *Portable residential spas* and *portable residential exercise spas*.

303.4 Covers. Heated pools and in-ground permanently installed *spas* shall be provided with a vapor retardant *cover*.

Exception: Where more than 70 percent of the energy for heating, computed over an operating season, is from site-recovered energy such as from a heat pump or solar energy source.





BOROUGH OF RINGWOOD
Building Department ■ Code Enforcement
Phone (973) 962-7880 Fax (973) 962-7823 building@ringwoodnj.net

POOL PACKET

SECTION TWO – PRIOR APPROVALS

Do not submit the construction permit until this application has been approved

INSTRUCTIONS

Complete and submit all of the following forms:

- Request for Zoning Approval
- Request for Health Department Approval
- Area, Bulk and Yard Requirements by Zoning Districts
- Request for Water Department Approval
- Dwelling Existence Certification
- Inspection Notice
- Acknowledgment of Fencing Regulations

Applicant provides:

- Copy of property survey. Survey must be original size and to scale.

INSTRUCTIONS

- Please print forms one-sided.
- Homeowner completes and signs each form where indicated.
- Mark up survey according to instructions on Zoning and Health forms.
- E-mail packet and survey or drop off at the Building Department.

You will be notified when the Prior Approval review is completed



BOROUGH OF RINGWOOD

Ringwood Zoning Official

Phone (973) 962-7880 ■ Fax (973) 962-7823 ■ building@ringwoodnj.net

Request for Zoning Approval

Owner's Name _____ Work Site _____

Address _____ Block _____ Lot _____

Daytime Phone _____ Email _____

- PROPOSED PROJECT:
- Above Ground Pool In Ground Pool
- Deck Patio Shed or Accessory Structure
- Addition Interior Renovations Other: _____

Dimensions: Length: _____ Width _____ Height _____

Land disturbance square footage: _____

You must provide a copy of your sealed site plan/property survey with the following notations:

- Sketch the proposed location and dimensions of your construction.
- Indicate the distance to all property lines. (See attached form for setbacks in your zone)

For Additions: Size of Addn _____ sq ft Land Disturbance of Addn _____ sq ft
 If construction is in whole or part over existing home, indicate what area of house is being raised.
 If all or portion of addition is an extension to footprint of home, sketch on and indicate dimensions.

Footprints disturbing more than 500 square feet of land require Site Plan Review by Borough Engineer \$150 fee to include:

- 4 sealed topographical site plans for preliminary review (3 hard copy, 1 electronic copy)
- 4 sealed foundation location plans prior to framing (3 hard copy, 1 electronic copy)
- 4 sealed "As Built" site plans prior to issuance of Certificate of Occupancy (3 hard copy, 1 electronic copy)

Signature of Homeowner _____ Date _____

For Office Use Only

Approved by _____ Date _____

Denied by _____ Date _____

Applicant Notified? Yes _____ No _____

Comments _____

Routed date _____

Health _____

Assessor _____

Zoning _____

Water _____



BOROUGH OF RINGWOOD

Health Department

Phone (973) 962-7079 ■ Fax (973) 962-7823

Request for Health Department Approval

Owner's Name _____ Work Site _____

Address _____ Block _____ Lot _____

Daytime Phone _____ Email _____

- Proposed Project:
- | | |
|--|---|
| <input type="checkbox"/> Above Ground Pool | <input type="checkbox"/> In Ground Pool |
| <input type="checkbox"/> Deck | <input type="checkbox"/> Patio |
| <input type="checkbox"/> Shed or Accessory Structure | |
| <input type="checkbox"/> Addition | <input type="checkbox"/> Interior Renovations |
| <input type="checkbox"/> Other: _____ | |

To approve your proposed project, the following information must be supplied:

1. On a copy of your site plan/property survey:
 - Sketch the proposed location of your construction.
 - Indicate the location of your septic system and well or public water service line from the street to the house.
 - Indicate the distances between all septic components, water lines or well and the proposed project.
2. A copy of your most recent pumping permit (if available).
3. For Additions and Interior Renovations:
 - An inside floor plan of all levels of the existing house with all rooms labeled.
 - An inside floor plan showing all the levels of the proposed structure with all rooms labeled.
 - Existing # of bedrooms _____ Proposed additional bedrooms _____ Total _____
 - Proposed additional square feet _____
 - Proposed additional bathrooms _____

Note: Be advised that your septic system may not be in conformance with state and local codes. Before approval for the work you have proposed can be granted, you may be required to upgrade your system to current standards.

Signature of Homeowner _____ Date _____

For Office Use Only

Denied by _____ Date _____

Comments _____

Applicant Notified? Yes _____ No _____

Approved by _____ Date _____

AREA, BULK AND YARD REQUIREMENTS BY ZONING DISTRICTS IN THE BOROUGH OF RINGWOOD, NEW JERSEY

Zone	Minimum Area Requirements					Maximum Bulk Requirements				Minimum Yard Requirements		
	District	Lot Area (Sq. Ft.)	Lot Width (Ft.)	Lot Depth (Ft.)	Maximum Disturbed Land Area %**	Improved Lot Coverage %***	Lot Coverage %***	Bldg. Ht. Principal Ft. Stories	Front Yard (Ft.)	Each Side Yard (Ft.)	Rear Yard Principal / Accessory	
R-20	Single-Family	20,000	100	175	50	35	25	35	2 1/2	35	15	35 / 20
R-40	Single-Family	40,000	150	200	30	25	20	35	2 1/2	35	30	50 / 35
R-40V and R-80V	Single-Family w/ Public Water	40,000	150	200	See Schedule	25	20	35/40	2 1/2	35	30	50 / 35
	Single-Family w/o Public Water	80,000	200	250	Below	20	18					
RT-40	One-Family & Two-Family	40,000	150	200	40	35	25	35	2 1/2	35	30	50 / 35
	EXISTING CONDITIONS											
	PROPOSED PROJECT											

Lot Coverage shall mean the percentage of a lot area which is occupied by buildings and accessory structures including swimming pools, porches, decks, chimneys and other related building appurtenances but not including walkways, driveways, patios, tennis courts, open parking areas and loading areas.

Improved Lot Coverage shall mean the percentage of lot area which is improved with principal and accessory buildings, structures and uses including, but not limited to, driveways, tennis courts, parking areas, garages, walkways, patios, loading areas, hard surfaces or other man-made improvements. Detention or retention basins shall be excluded from such calculations provided same is constructed of natural materials.

Maximum Disturbed Land Area shall mean all land outside of the allowable disturbed areas shall be left in its natural state and no trees, shrubs, vegetated ground cover, top soil or other natural features shall be moved or altered.

Zone	Lot Area (Sq. Ft.)	Maximum Disturbed Land Area* (% of Lot)
R-40V** and R-80V	0 — 40,000	30.0%
	40,001 — 50,000	28.0%
	50,001 — 60,000	25.0%
	60,001 — 70,000	23.2%
	70,001 — 80,000	21.0%
	80,001 — 90,000	19.5%
	90,001 — 100,000	18.0%
	100,001 — 110,000	17.0%
	110,001 — or more	16.0%

Complete this section and sign below:

Is any portion of the lot a designated floodway or flood hazard area? Yes ___ No ___

Is a wetland area located on the lot? Yes ___ No ___

Signature of Homeowner: _____



Borough of Ringwood
 Department of Public Works
 Office of the Water Superintendent
 973-475-7103

REQUEST FOR APPROVAL FOR PROPOSED POOL

Date _____

Name _____ Address _____

Block _____ Lot _____ Telephone _____

Dimensions of Pool _____

Capacity of Pool in Gallons (Length x Width x Average Depth) _____

Source of Water Supply: Municipal Water Supply _____

Private Well _____

Purchase from Private Vendor _____

Anticipated Fill Date: _____

Approved _____ Conditionally Approved _____ (See Comments)

Not Approved _____ (See Comments)

Comments _____

 Director of Public Works/Water Superintendent

CHAPTER 18 – WATER

18-10.2 Use of Water to Fill Swimming Pools

- a. No person shall make use of any water from any of the water mains or supply pipes of this Borough except in the manner provided in this Chapter.
- b. All water customers having a swimming pool in excess of two thousand five hundred (2,500) gallons capacity shall be required to obtain approval from the Water Superintendent to fill same. Prior to granting permission, the Water Superintendent shall consider the demands upon the system, other applicants for like purpose, and shall designate time or times when water may be taken from the system for this purpose by the applicant. (1985 Code, Section 19-1.4)



BOROUGH OF RINGWOOD

Building Department

Phone (973) 962-7880 ■ Fax (973) 962-7823 ■ building@ringwoodnj.net

Certification of Highlands Exemption #5

Date: _____

Owner: _____

Property Address: _____

Block: _____ Lot: _____

Description of Project: _____

The aforementioned project is located wholly within the Highlands Preservation Area and Highlands regulations restrict development. However, the Highlands Rules at N.J.A.C 7:38-2.3 set forth various exemptions. Borough of Ringwood tax records indicate that this dwelling was in existence prior to August 10, 2004 and, therefore, qualifies for **Exemption #5** defined as: "Any improvement to a lawfully existing single-family dwelling in existence on August 10, 2004, including but not limited to an addition, garage, shed, driveway, porch, deck, patio, swimming pool, or septic system, as long as the improvement maintains the use as a single-family dwelling as defined by code or ordinance in the municipality in which the dwelling is located and does not permit use of the structure as a multiple until dwelling."

Therefore, the proposed Project is deemed **exempt** from the provisions of the Highlands Rules, subject to the following limitation (s):

"If the Borough of Ringwood subsequently determines the information submitted to obtain this decision is inaccurate, the exemption shall be void."

This exemption determination is limited to the land area and specific scope of the activities described herein or as shown on a survey of the property. This determination does not eliminate the need for any permits, approvals, or certifications required by any other Federal, State, County, or municipal review agency with jurisdiction over this activity, including, but not limited to, freshwater wetlands or flood hazard permits or review of storm-water management.

Homeowner Date

Assessor Date

Highlands Exemption Designee Date



BOROUGH OF RINGWOOD

Building Department ■ Code Enforcement

Phone (973) 962-7880 ■ Fax (973) 962-7823 ■ building@ringwoodnj.net

Remember to Call for Inspections !!

NOTICE

It is the joint responsibility of the Homeowner and the Contractor to ensure that all required inspections are scheduled throughout construction and upon completion of the work.

- The Uniform Construction Code states, "Upon completion of the building or structure and before issuance of a certificate of use and occupancy required herein, a *final inspection shall be made.*" NJAC 5:23-2.18(d)
- A building or structure hereafter erected shall not be used or occupied in whole or in part until a form of certificate of occupancy shall be issued by the Construction Official. NJAC 5:23-2.23(a)

Noncompliance of the above provisions of the UCC is a violation, and pursuant to NJAC 5:23-2.31(b)4, a monetary penalty shall be issued immediately.

Therefore, please take note that if final inspections are not called for within a reasonable length of time after completion of the work, and prior to occupancy of a new dwelling or addition, a **violation notice will be issued along with a penalty of up to \$2,000.00.**

Homeowners take note:

Final payment to the contractor is not required to be made before a final inspection is performed. [NJ Division of Consumer Affairs Rule NJAC 13:45A-16.2(a)10.ii]

- | | |
|-----------------|--|
| Building | <input type="checkbox"/> Pre-loc (before concrete) |
| | <input type="checkbox"/> Post-loc (before backfilling) |
| | <input type="checkbox"/> Final (when pool is complete) |
| Plumbing | <input type="checkbox"/> Rough (underground piping) |
| | <input type="checkbox"/> Gas Line Test |
| | <input type="checkbox"/> Final – Heater inspection |
| Electric | <input type="checkbox"/> Bonding and G.F.I. |
| | <input type="checkbox"/> Trench |
| | <input type="checkbox"/> Final |

Owner Signature _____

Date _____

Signature _____ Date: _____

SECTION 305

BARRIER REQUIREMENTS

305.1 General. The provisions of this section shall apply to the design of barriers for pools and spas. These design controls are intended to provide protection against the potential drowning and near drowning by restricting access to such pools or spas. These requirements provide an integrated level of protection against potential drowning through the use of physical barriers and warning devices.

Exceptions:

1. Spas and hot tubs with a lockable *safety cover* that complies with ASTM F 1346.

305.2 Outdoor swimming pools and spas. Outdoor pools and spas and indoor swimming pools shall be surrounded by a barrier that complies with Sections 305.2.1 through 305.7

305.2.1 Barrier height and clearances. Barrier heights and clearances shall be in accordance with all of the following:

1. The top of the barrier shall be not less than 48 inches (1219 mm) above grade where measured on the side of the barrier that faces away from the pool or spa. Such height shall exist around the entire perimeter of the barrier and for a distance of 3 feet (914 mm) measured horizontally from the outside of the required barrier.
2. The vertical clearance between grade and the bottom of the barrier shall not exceed 2 inches (51 mm) for grade surfaces that are not solid, such as grass or gravel, where measured on the side of the barrier that faces away from the pool or spa.
3. The vertical clearance between a surface below the barrier to a solid surface, such as concrete, and the bottom of the required barrier shall not exceed 4 inches (102 mm) where measured on the side of the required barrier that faces away from the pool or spa.
4. Where the top of the pool or spa structure is above grade, the barrier shall be installed on grade or shall be mounted on top of the pool or spa structure. Where the barrier is mounted on the top

of the pool or spa, the vertical clearance between the top of the pool or spa and the bottom of the barrier shall not exceed 4 inches (102 mm).

305.2.2 Openings. Openings in the barrier shall not allow passage of a 4-inch-diameter (102 mm) sphere.

305.2.3 Solid barrier surfaces. Solid barriers that do not have openings shall not contain indentations or protrusions that form handholds and footholds, except for normal construction tolerances and tooled masonry joints.

305.2.4 Mesh fence as a barrier. Mesh fences, other than chain link fences in accordance with Section 305.2.7, shall be installed in accordance with the manufacturer's instructions and shall comply with the following:

1. The bottom of the mesh fence shall be not more than 1 inch (25 mm) above the deck or installed surface or grade.
2. The maximum vertical clearance from the bottom of the mesh fence and the solid surface shall not permit the fence to be lifted more than 4 inches (102 mm) from grade or decking.
3. The fence shall be designed and constructed so that it does not allow passage of a 4-inch (102 mm) sphere under any mesh panel. The maximum vertical clearance from the bottom of the mesh fence and the solid surface shall not be more than 4 inches (102 mm) from grade or decking.
4. An attachment device shall attach each barrier section at a height not lower than 45 inches (1143 mm) above grade. Common attachment devices include, but are not limited to, devices that provide the security equal to or greater than that of a hook-and-eye type latch incorporating a spring-actuated retaining lever such as a safety gate hook.
5. Where a hinged gate is used with a mesh fence, the gate shall comply with Section 305.3.
6. Patio deck sleeves such as vertical post receptacles that are placed inside the patio surface shall be of a nonconductive material.

7. Mesh fences shall not be installed on top of onground *residential* pools.

305.2.5 Closely spaced horizontal members. Where the barrier is composed of horizontal and vertical members and the distance between the tops of the horizontal members is less than 45 inches (1143 mm), the horizontal members shall be located on the pool or spa side of the fence. Spacing between vertical members shall not exceed 1 ¾ inches (44 mm) in width. Where there are decorative cutouts within vertical members, spacing within the cutouts shall not exceed 1 ¾ inches (44 mm) in width.

305.2.6 Widely spaced horizontal members. Where the barrier is composed of horizontal and vertical members and the distance between the tops of the horizontal members is 45 inches (1143 mm) or more, spacing between vertical members shall not exceed 4 inches (102 mm). Where there are decorative cutouts within vertical members, the interior width of the cutouts shall not exceed 1 ¾ inches (44 mm).

305.2.7 Chain link dimensions. The maximum opening formed by a chain link fence shall be not more than 1 ¾ inches (44 mm). Where the fence is provided with slats fastened at the top and bottom which reduce the openings, such openings shall not be more than 1 ¾ inches (44 mm).

305.2.8 Diagonal members. Where the barrier is composed of diagonal members, the maximum opening formed by the diagonal members shall not be more than 1 ¾ inches (44 mm). The angle of diagonal members shall be not greater than 45 degrees (0.79 rad) from vertical.

305.2.9 Clear zone. There shall be a clear zone of not less than 36 inches (914 mm) between the exterior of the barrier and any permanent structures or equipment such as pumps, filters and heaters that can be used to climb the barrier.

305.2.10 Poolside barrier setbacks. The pool or spa side of the required barrier shall not be less than 20 inches (508 mm) from the water's edge.

305.3 Gates. Access gates shall comply with the requirements of Sections 305.3.1 through 305.3.3 and shall be equipped to accommodate a locking device. Pedestrian access gates shall open outward away from the pool or spa, shall be self-closing and shall have a self-latching device.

305.3.1 Utility or service gates. Gates not intended for pedestrian use, such a utility or service gates, shall remain locked when not in use.

305.3.2 Double or multiple gates. Double gates or multiple gates shall have at least one leaf secured in place and the adjacent leaf shall be secured with a self-latching device. The gate and barrier shall not have openings larger than ½ inch (12.7 mm) within 18 inches (457 mm) of the latch release mechanism. The self-latching device shall comply with the requirements of Section 305.3.3.

305.3.3 Latches. Where the release mechanism of the self-latching device is located less than 54 inches (1372 mm) from grade, the release mechanism shall be located on the pool or spa side of the gate not less than 3 inches

(76 mm) below the top of the gate, and the gate and barrier shall not have openings greater than ½ inch (12.7 mm) within 18 inches (457 mm) of the release mechanism.

305.5 Onground residential pool structure as a barrier. An onground *residential* pool wall structure or a barrier mounted on top of an onground *residential* pool wall structure shall serve as a barrier where all of the following conditions are present:

1. Where only the pool wall services as the barrier, the bottom of the wall is on grade, the top of the wall is not less than 48 inches (1219 mm) above grade for the entire perimeter of the pool, the wall complies with the requirements of Section 305.2 and the pool manufacturer allows the wall to serve as a barrier.
2. Where a barrier is mounted on top of the pool wall, the top of the barrier is not less than 48 inches (1219 mm) above grade for the entire perimeter of the pool, and the wall and the barrier on top of the wall comply with the requirements of Section 305.2.
3. Ladders or steps used as means of access to the pool are surrounded by a barrier that meets the requirements of Section 305.
4. Openings created by the securing, locking or removal of ladders and steps do not allow the passage of a 4-inch (102 mm) diameter sphere.
5. Barriers that are mounted on top of onground *residential* pool walls are installed in accordance with the pool manufacturer's instructions.

305.6 Natural barriers. In the case where the pool or spa area abuts the edge of a lake or other natural body of water, public access is not permitted or allowed along the shoreline, and required barriers extend to and beyond the water's edge not less than 18 inches (457 mm), a barrier is not required between the natural body of water shoreline and the pool or spa.

305.7 Natural topography. Natural topography that prevents direct access to the pool or spa area shall include but not be limited to mountains and natural rock formations. A natural barrier approved by the governing body shall be acceptable provided that the degree of protection is not less than the protection afforded by the requirements of Sections 305.2 through 305.5.

